

QUEEN LIGHT

Compact HF welding machine

Model **LW-5500AP**

NEW concept !

Compact sophisticated
HF welding machine

Developed with the purpose
for machine cost saving

Machine promises that it works
high efficiency and
with maximum high power

3 stages power adjustment
realize from small power work
to full power work easily

Machine has created with
a concept of trouble free and
efficiency by the Queen Light 's
long term experiences
in this field

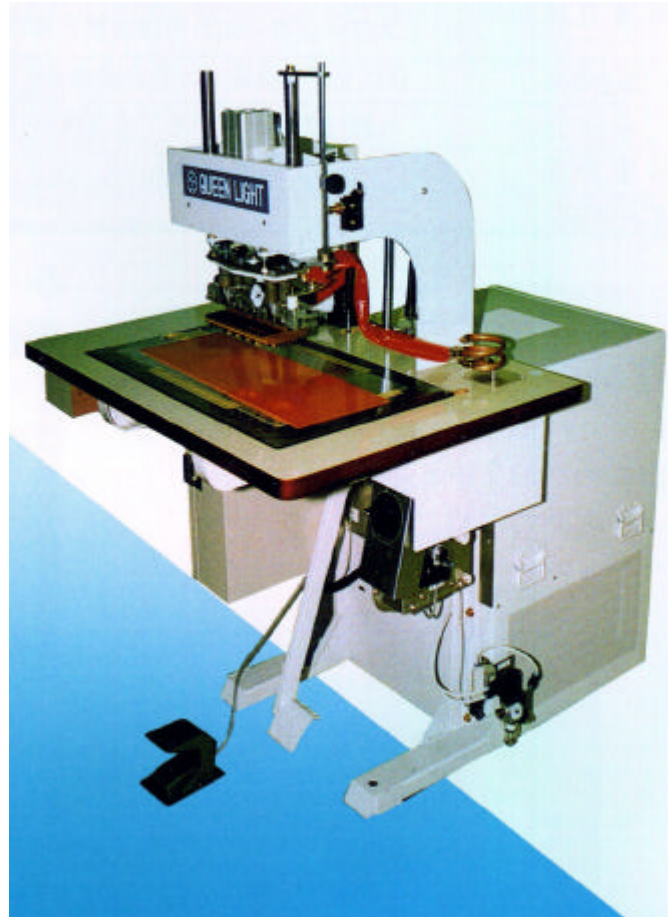

Any where at any time consult with Queen Light
We whenever present most suitable machine for your work

The compact HF welding machine which is the fruit from **QUEEN LIGHT 's** long-term experiences and know-how.

The well-built machine press assures that you can enjoy the machine performance of which shade different from traditional machine.

On the other hand single press machine originally has no switching contact in HF circuit and the most important point in machine operation is that a machine not only be free from danger but also be immune to breakdown.

This machine was originally created under such concept of which has no part to be cause for trouble and this concept presents customer really free from such troubles.

Even in the case when near work is operated operator can press the material by manual in prior of electric field is impressed for their safety, therefore it is no chance that pressing error on the product or injury for the machine operator is happening.

Furthermore, pressure can be adjusting in manual freely, a work that requires subtle pressure would become just easy work.

In addition to HF welding machine **Queen Light** provides various welding systems such as Hot-air sealers, Heated plate with continuous feed system, Impulse sealers, Hot-wedge welders, Ultrasonic welders, etc, therefore your inquiry for such heating system for processing industrial fabrics, thermo plastics shall always be welcomed.

Compact HF radio welding machine

Model LW-5500AP

Always to serve for customer ' s satisfactions.

Queen Light Electronic Ind., Ltd.

A machine supplier for industrial fabric user,

Outside drawing

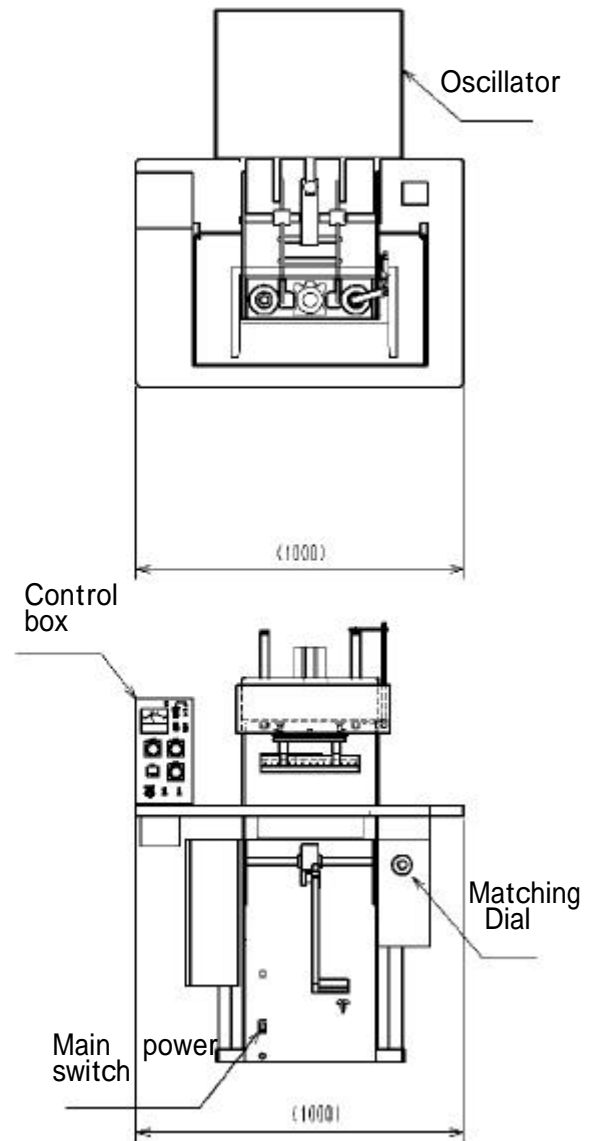
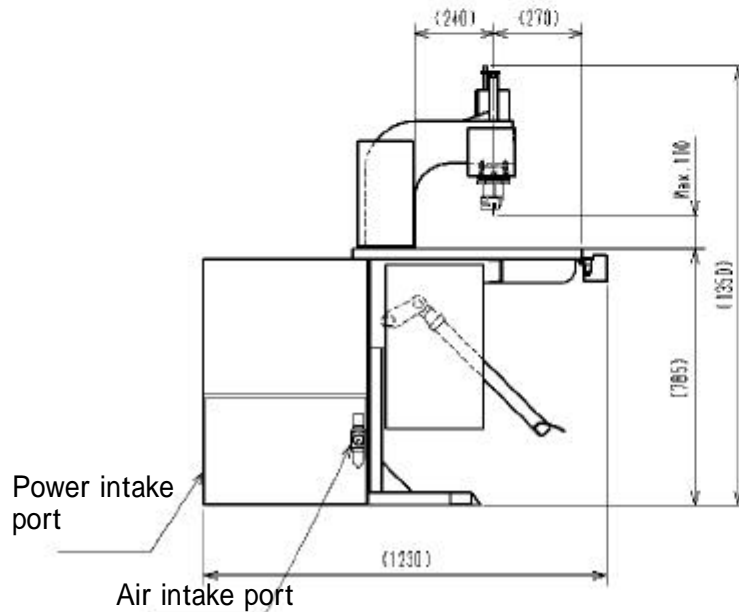

Specifications

Model	LW-5500AP	Power required	3P 200V +-10% 50/60Hz
Power consumption	Abt. 9 KVA	Press arm	C shape arm
Throat depth	260mm	Press system	By manual foot press with Aux. air cylinder
Upper/lower Electrode distance	Max. 200mm Normal 100mm adjustable	Upper electrode	Bar type mold holder L= 300mm
Lower electrode	400 x 700mm	Work height	785mm
Control	Manual / Auto	Power out-put	Max. 4.5 KW (3 stage change over possible)
Oscillating frequency	40.46 MHz	Oscillation system	Coaxial resonance oscillation system
Matching system	Manual matching dial system		
Prevention system	Anode current over road stop system	Spark prevention	Standard type available
Option (not include in standard machine)	Ultra high sensitive type spark prevention system (A class) Auto matching system with preset switch(High/ Low error sensor and indication) Anode current rise time automatic control system (Freely adjustable) Heater built-in electrode holder (length 300mm / 600mm) Heater built-in electrode holder flat plate type (135x200mm · 200x250mm)		

* Subject may be changed without notes.

Manufacture

Sales

QUEEN LIGHT ELECTRONIC IND., LTD.

576-1 Minato, Wakayama City, Japan

Phone 8173-431-6245

Fax 8173-433-8815

E-mail : info@queenlight.co.jp

URL : <http://www.queenlight.co.jp>